

Schutte

**HOGerizer™ Pallet
Scrap Grinder**

Produces a fine, clean,
marketable grind in just one pass.



Schutte

The first name in hammer mills that last

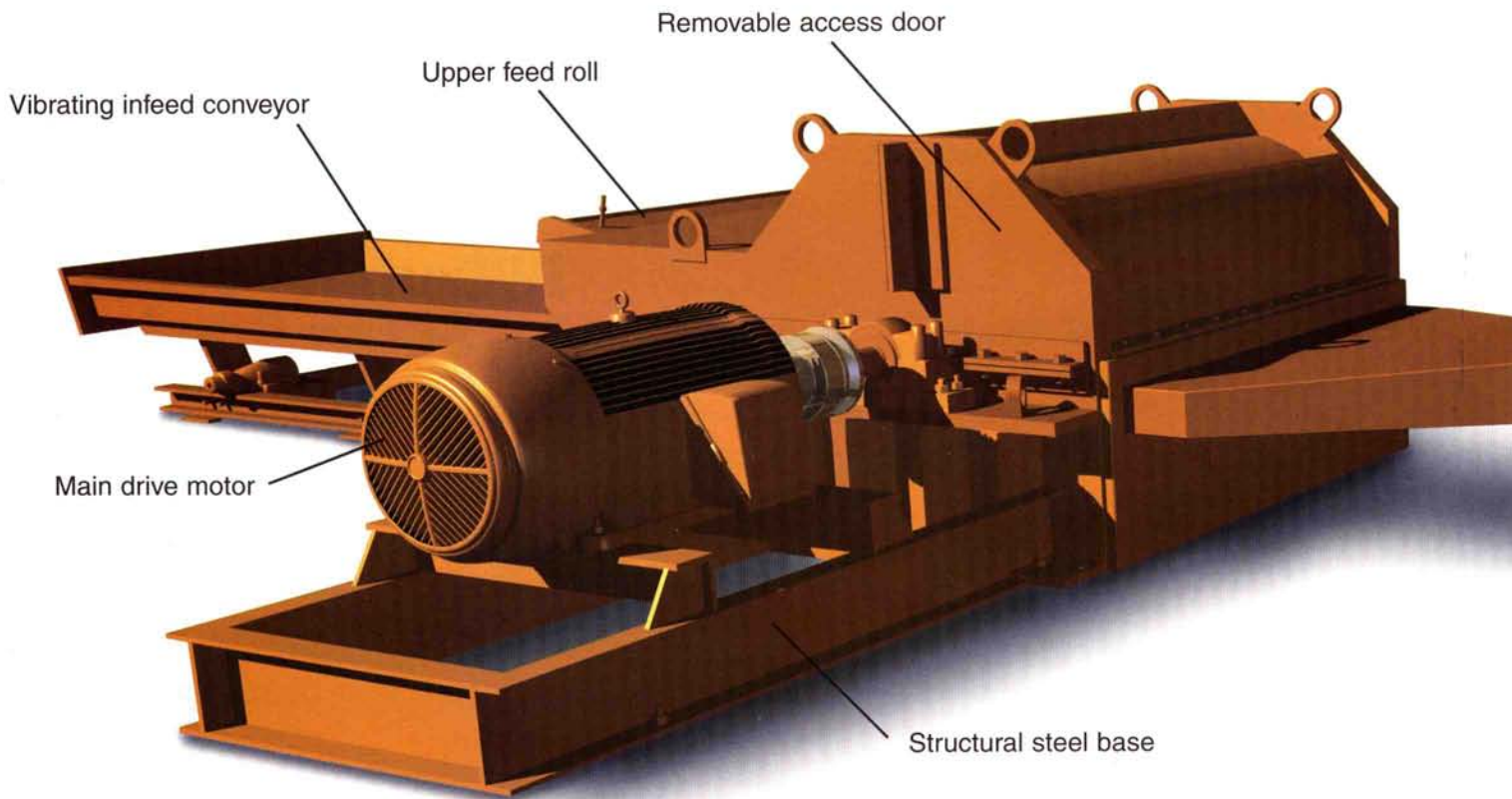

A breakthrough concept

The Schutte HOGerizer™ is the practical, modern and environmentally safe way to get rid of scrap wooden pallets. The completely integrated system feeds pallets automatically, removes all nails, screws and staples, and produces a finely ground mulch - in a single pass. No secondary operations of any kind are needed. And it meets all EPA, DEC and other government requirements for the safe disposal of solid waste.



Handles full size pallets

Standard 48" wide pallets are placed on the vibrating steel bed, nails and all, and fed into the mouth of the unit where four rows of heat-treated steel hammers "hogerizes" them. The finely-ground particles, along with the nails and other tramp iron, are sucked into an automatic rotary drum magnetic hump tunnel by a powerful 40-50 HP material handling fan.

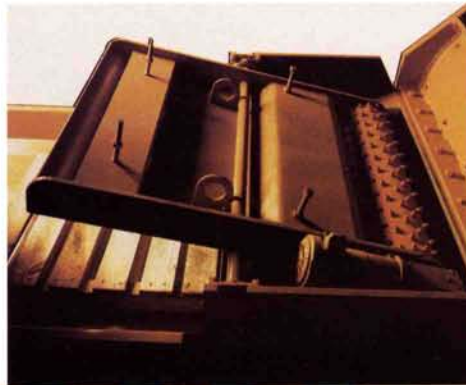

The floating, counterbalanced design of the upper feed roll on the power infeed provides positive action that "walks" the pallet up and in.

Completely removes nails

In a specially-designed automatic rotary drum magnetic hump tunnel, the mixture suddenly changes direction, momentarily reducing its velocity. Eriez Superbrute permanent plate magnets "reach out" and pull the nails and other metal objects from the flow. The ground wood continues through the fan blades and into a trailer to be hauled away, into storage, or for further processing.

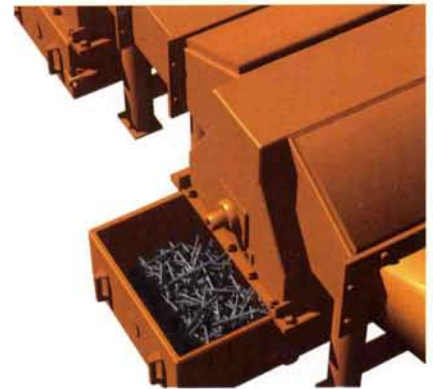

New design of automatic rotary drum magnetic hump tunnel features a powerful material handling fan and magnet system to remove nails from ground product.

Automatic rotary drum magnetic hump tunnel

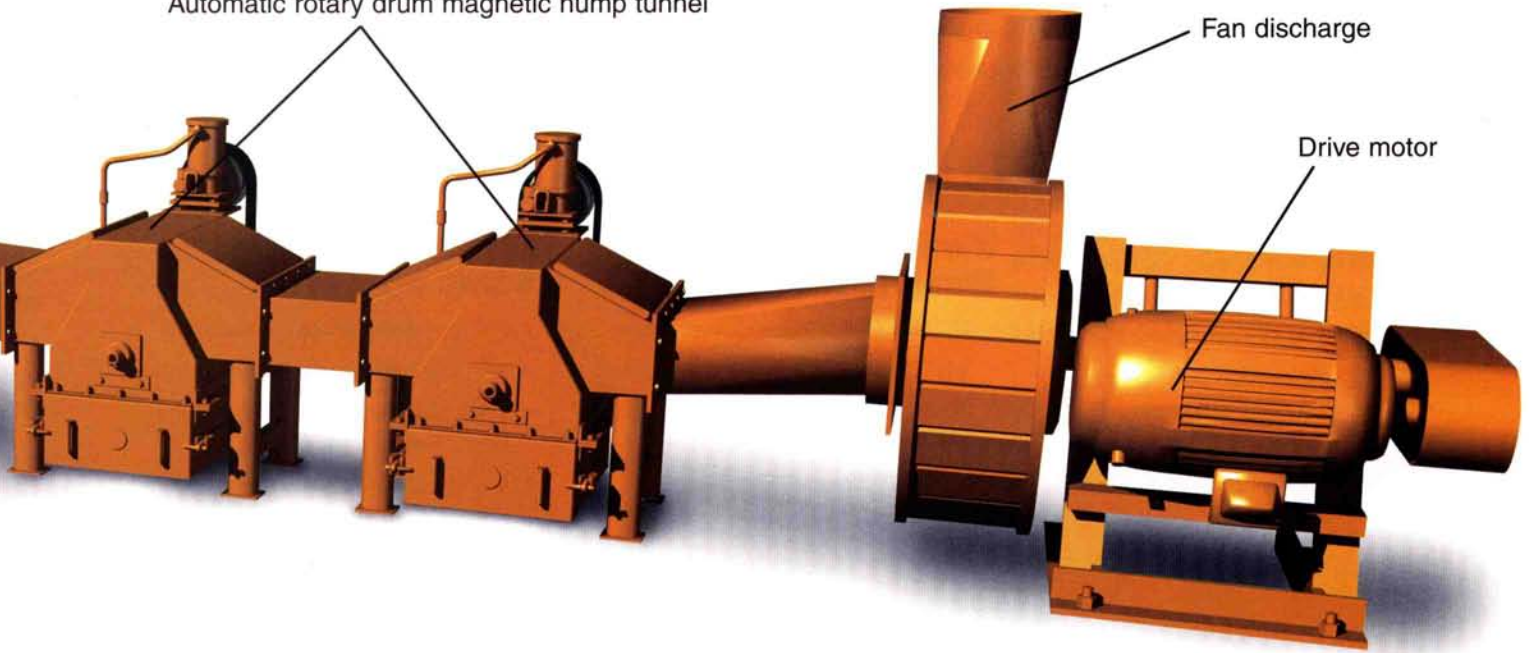

The fine, clean grind produced by the HOGerizer is resellable as boiler fuel, animal bedding or garden mulch.



Pallet chippers and ordinary hogs leave large splinters and coarse chunks - not suitable for resale.

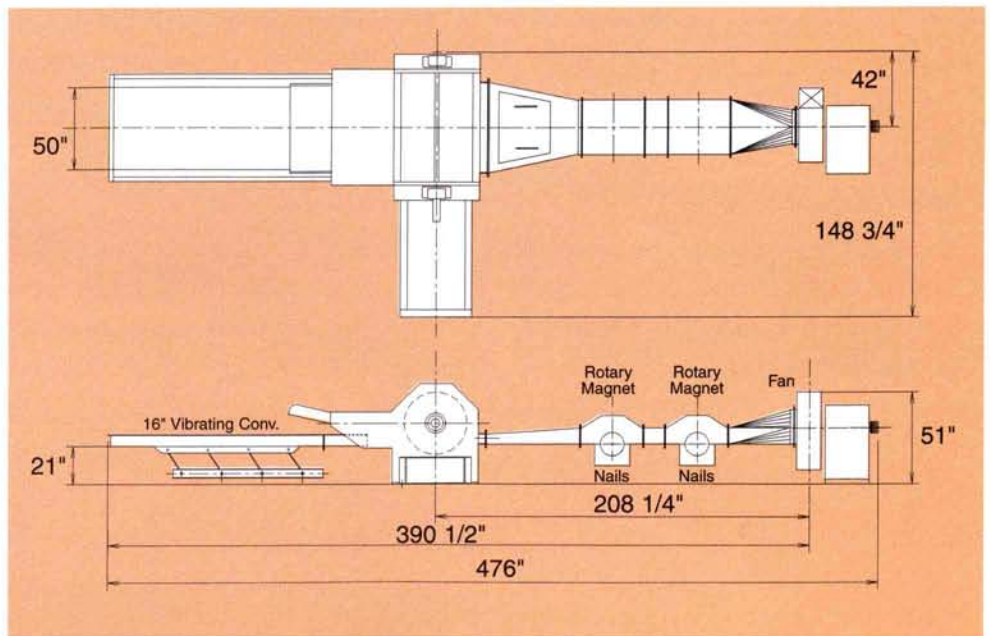

New HOGerizer Pallet Scrap Grinder Models

Schutte now offers the Model 4235 and Model 3035 Pallet Scrap Grinders, smaller units for processing wooden pallet scrap and other wood scrap materials into a uniform, first quality

grind. These models are ideal for lumber mills, furniture plants, recycling facilities and other operations for processing trim scrap, cardboard, boxes, paper products and more.

Better built for a better value.

The HOGerizer offers the innovative features and uncompromising quality in construction and workmanship that you can only get from a Schutte product. Your initial investment is usually recovered in a remarkably short time and maintenance costs are minimal.

Specifications

Model 5635

- 2" Thick Boiler Plate Construction
 - 3/8" Thick Replaceable Wear Liners
 - 7-1/4" Diameter (Barrel Section) Heat Treated Alloy Shaft
 - 4-7/16" Tapered Roller Bearings
 - (25) 2" Rotor Arms (24 Space Rotor)
 - (4) 1-3/4" Diameter Hammer Rods
 - Twin 3" Thick 35" Diameter Internal Flywheels
 - 3/4" Thick Replaceable Grate
 - 45HV1 Separate Fan Unit (8,200 CFM with 40 Horsepower Motor)
 - Automatic Rotary Drum Magnetic Hump Nail Removal Tunnel
 - Capacity: 250-300 Pallets per hour; 7-9 Tons Trim Scrap per hour
- Out-Feed: Animal Bedding, Fuel, Mulch

Model 4235 Pallet Scrap Grinder

- 2" Thick Boiler Plate Construction
 - 3/8" Thick Replaceable Wear Liners
 - 7-1/4" Diameter (Barrel Section) Heat Treated Alloy Shaft
 - 4-7/16" Tapered Roller Bearings
 - (12) 2" Rotor Arms
 - (36) 1-3/4" Raked Hammers
 - (4) 1-3/4" Diameter Hammer Rods
 - Twin 3" Thick 35" Diameter Internal Flywheels
 - 3/4" Thick Replaceable Grate
 - Capacity: 4 Tons Trim Scrap per hour
- Out-Feed: Animal Bedding, Fuel, Mulch

Model 3035 Pallet Scrap Grinder

- 2" Thick Boiler Plate Construction
 - 3/8" Thick Replaceable Wear Liners
 - 7-1/4" Diameter (Barrel Section) Heat Treated Alloy Shaft
 - 4-7/16" Tapered Roller Bearings
 - (12) 2" Rotor Arms
 - (24) 1-3/4" Raked Hammers
 - (4) 1-3/4" Diameter Hammer Rods
 - Twin 3" Thick 35" Diameter Internal Flywheels
 - 3/4" Thick Replaceable Grate
 - Capacity: 2 Tons Trim Scrap per hour
- Out-Feed: Animal Bedding, Fuel, Mulch

Schutte...the first name in pulverizers that last

The HOGerizer complements a complete line of pulverizers and industrial grinders offered by Schutte Pulverizer. Schutte has been an industry leader for over 60 years with simpler, safer, longer-lasting hammer mills of uncompromising quality. Every Schutte machine is built to deliver superior performance, day after day, year after year, under the most severe operating conditions.

Schutte

The first name in hammer mills that last

For more information on the HOGerizer or on our complete line of equipment contact:
Schutte Pulverizer Co., Inc. • 61 Depot Street • P.O. Box 546 • Buffalo, NY 14240-0546
Toll-Free: 1-800-4GRIND4 • Telephone: (716) 855-1555 • FAX: (716) 855-3417
e-mail: SPCGRINDER@aol.com